

## Selecting Your SGMSH Sigma II Servo System

First, select the Sigma II servomotor suited for your application using SigmaSize: the Yaskawa servomotor sizing software, available at no charge. (Request SigmaSize software via e-mail, at: literature@yaskawa.com).

Use the diagram below to locate and identify the components of your system. Each item is letter-coded and cross-referenced in the option tables on the following pages.

### System Configuration

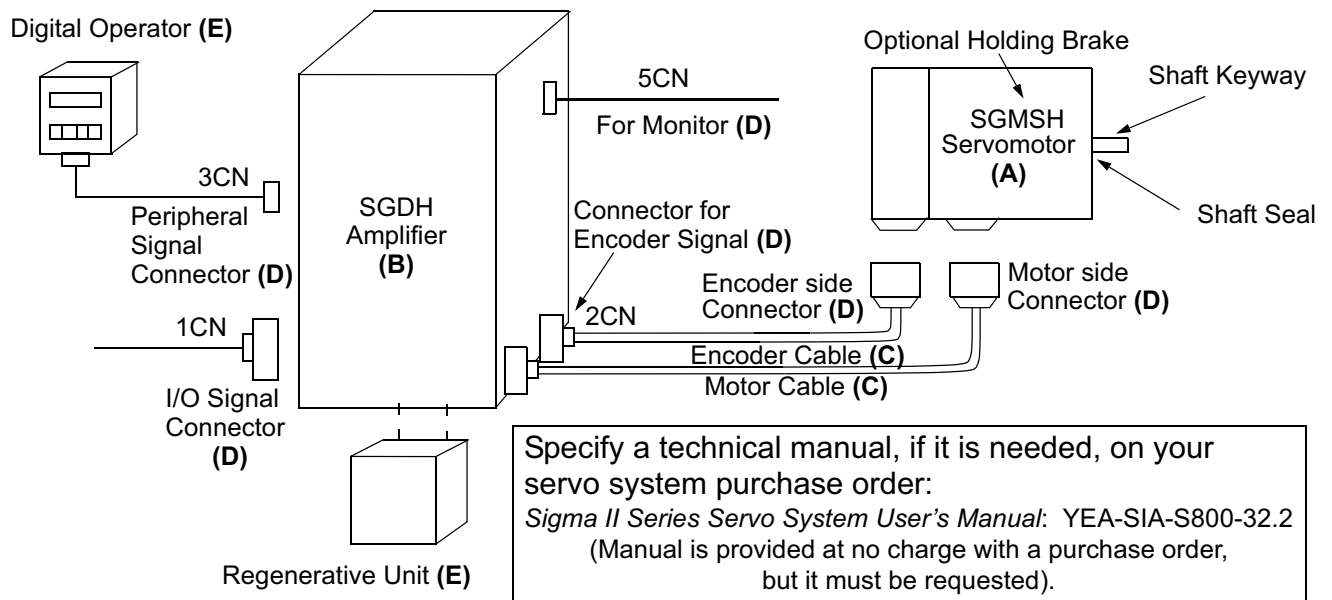

### Model Number Designation

**SGMSH - 10 A C A 6 [1]**

